

## INSTRUCTION MANUAL SPU-DIM-C02



### Key features

- 1 Channel 0/1-10V signal Input, 1 Channel PWM Output.
- Analogue dimming driver, receiving a standard 1-10V dimming signal input.
- 0-100% dimming range via the logarithmic curve, perfect for the human eye.
- 256 greyscale values; smooth transition without flickering.
- Works with a power repeater for unlimited output amplification.
- Compatible with a 1-10 controller or 1-10V analogue dimmer. Smooth dimming curve, directly proportional to the standard voltage curve.

### Technical characteristics

Ref.	Input Voltage	Output Current	Output Power	Observations
9955903	12 - 36 VDC	1 x 8 A	1 x ( 96 - 288 ) W	Constant voltage

### Function overview

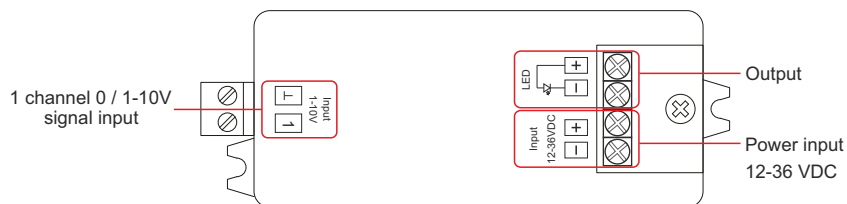

### Dimensions

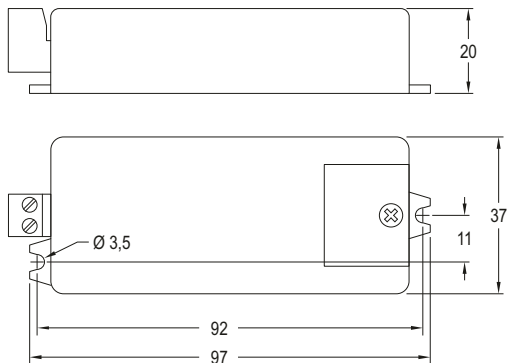

### Control modes

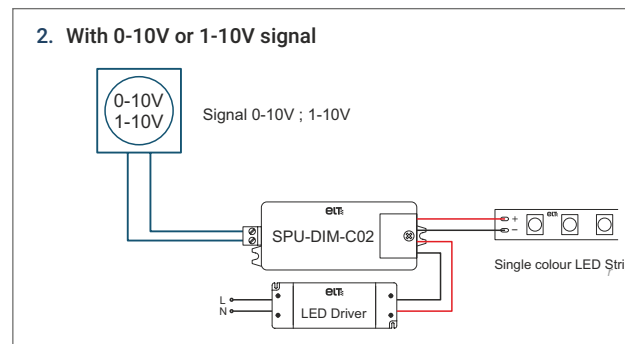
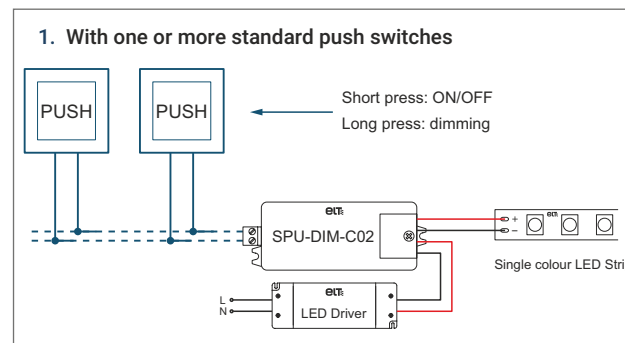

### Operation

Connect the device according to the wiring diagram.

### PUSH DIM

With the push switch connected, click the ON/OFF button. Press and hold down the button to increase / decrease the light intensity.

### Safety warnings

- 1) This product must be installed and serviced by qualified personnel.
- 2) IP20. Protect from sun and rain. For outdoor installations, make sure it is housed inside a waterproof enclosure.
- 3) Always ensure the device is installed in a properly ventilated area to avoid overheating.
- 4) Make sure that the output voltage of any LED power supply used complies with the working voltage of the product.
- 5) Never connect any cables while the power is on. To avoid short circuits, check the connections are correct before switching on.
- 6) Check that cables are securely attached to the terminal blocks.
- 7) Please contact your supplier for updated information.
- 8) DO NOT install with power connected to the device.
- 9) DO NOT expose the device to humidity.